



## INSTRUCTION MANUAL

### RAKE ATTACHMENT

Models: SG36, SG42, SG46, & SG52



# RAKE ATTACHMENT INSTRUCTIONS

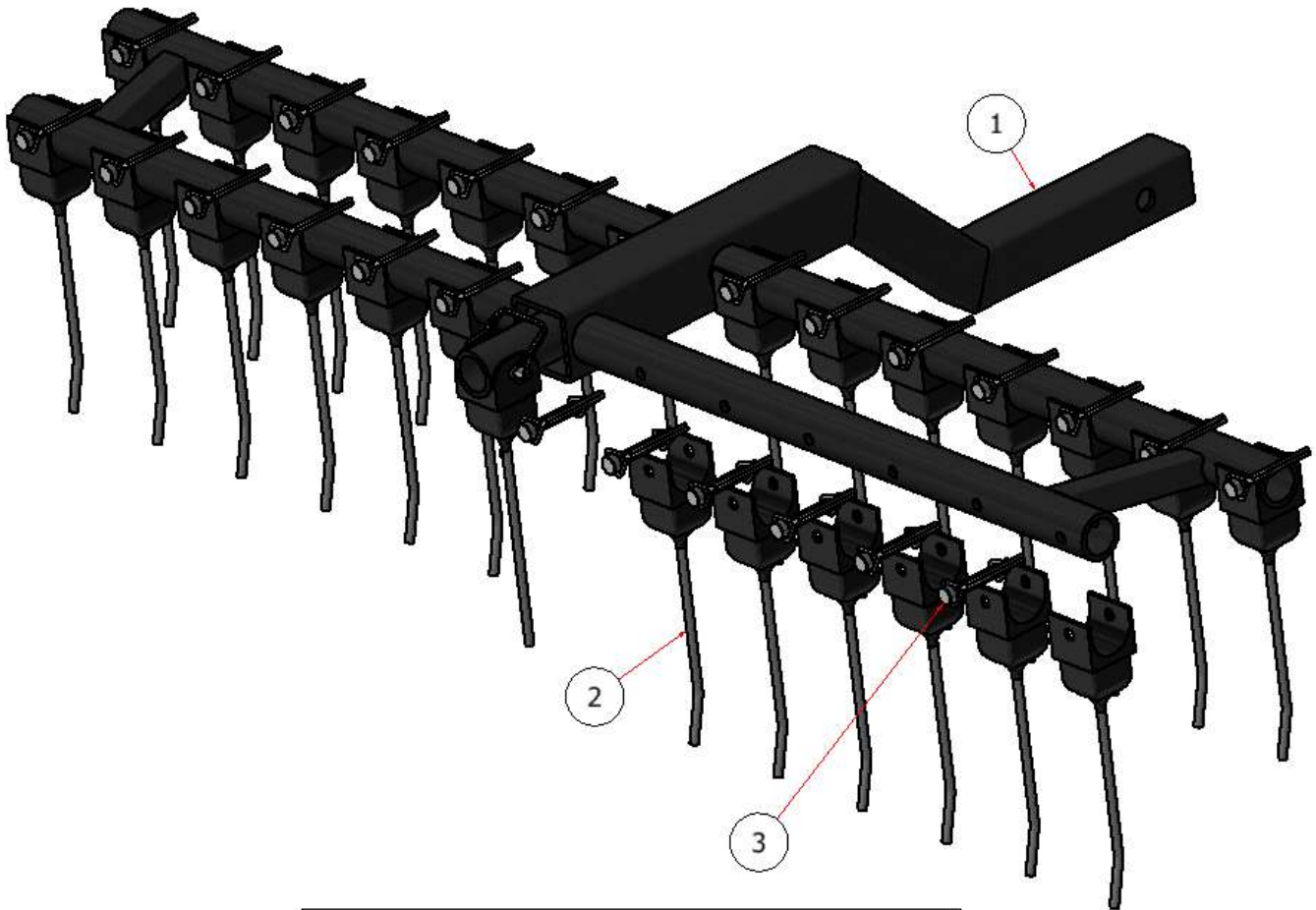

PARTS LIST			
ITEM	QTY	PART NUMBER	DESCRIPTION
1	1	W-PL037	FRAME, RAKE ATTACHMENT
2	27	DR10001	TINE, RAKE ASSEMBLY
3	27	C60318	PIN, WIRE-LOCK CLEVIS

## RAKE ATTACHMENT INSTRUCTIONS

### STEP ONE:

#### NOTE:

- If your machine is already equipped with the hydraulic lift kit (A10081), proceed to step eight.
- Some parts not shown for clarity.

- Set the plow hitch in the frame by resting the front of the plow hitch on top of the frame rail and the back of the hitch will attach to the bottom of the frame rail.

**ASSEMBLY TIP:** Use a floor jack or block of wood to support the back of the plow hitch.

- Attach the plow hitch to the frame using the top brackets and (6) 3/8" X 2-3/4" carriage bolts and (6) 3/8" nuts provided with the kit.

**NOTE:** Note the orientation of the back brackets. Be sure the tab is facing the correct direction (One will face left and the other will face right) so the hitch is centered in the frame.

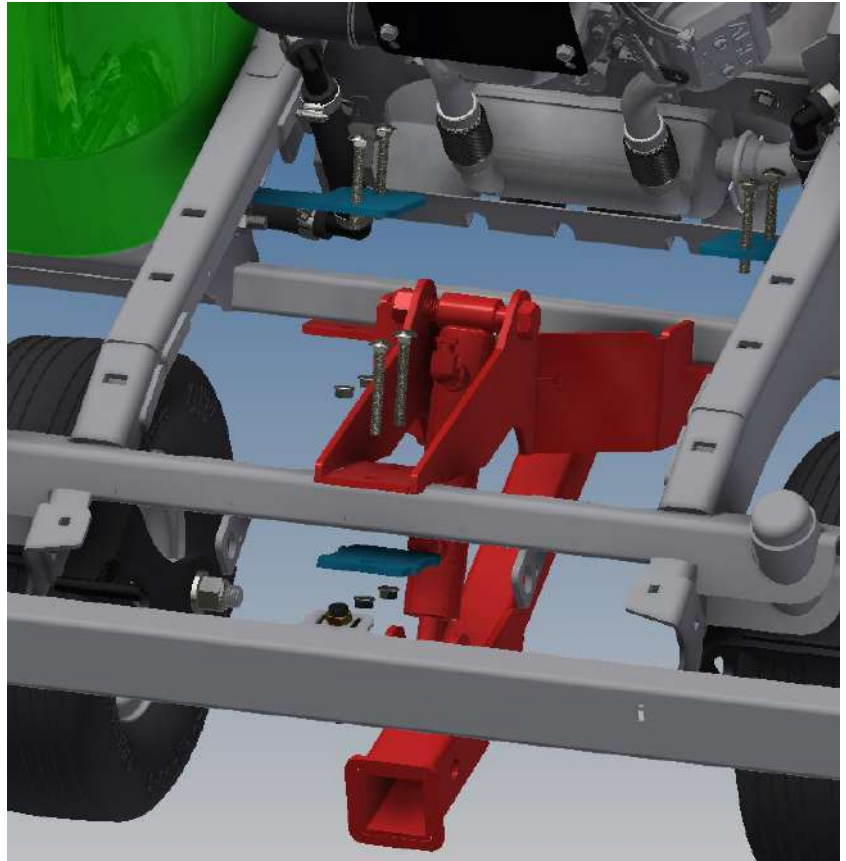

Back bracket

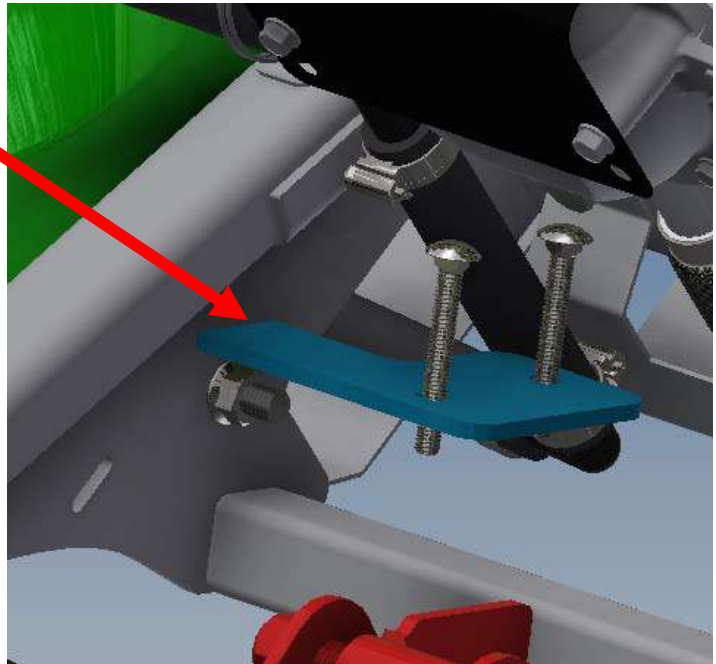

## RAKE ATTACHMENT INSTRUCTIONS

- After the hitch is tightened to the frame adjust the exhaust shield so it rests in the grooves of the plow hitch.

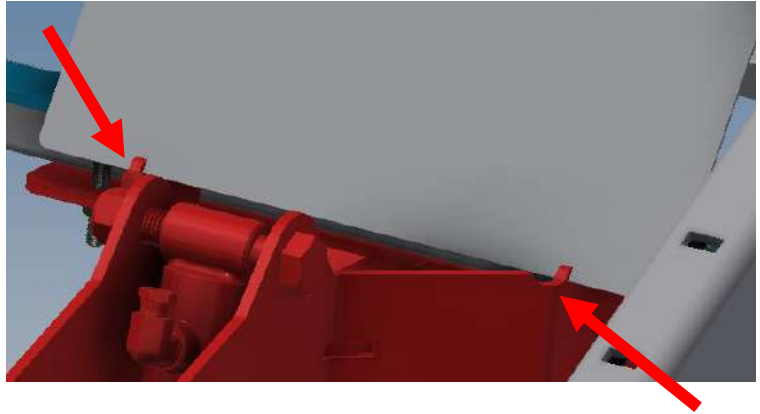

### STEP TWO:

- Remove the existing (2) bolts from the gas tank support.



- Attach the control valve assembly to the side of the upright using (2) 3/8 X 1" carriage bolts provided with the kit and reuse the nuts that were removed.

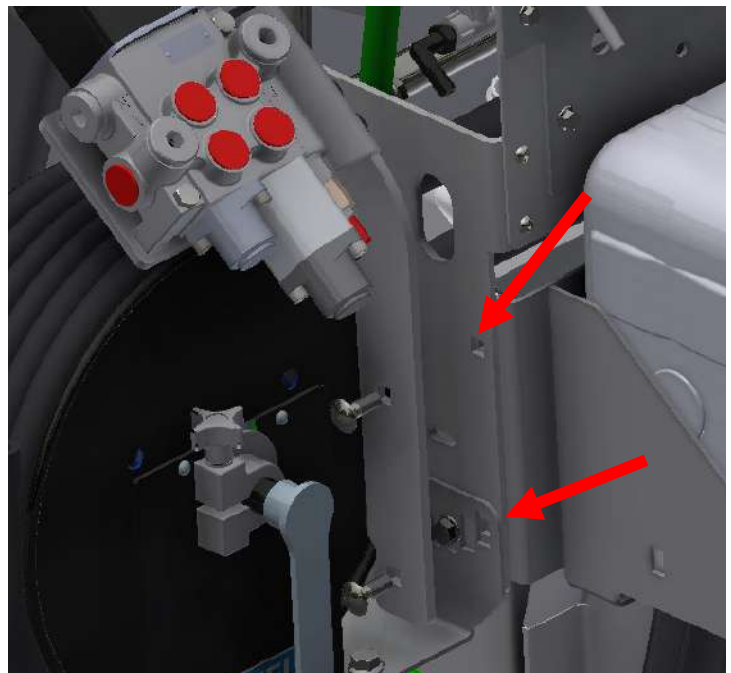



## RAKE ATTACHMENT INSTRUCTIONS

### STEP THREE:

- Locate the hose that runs from the bottom port of the hopper control valve down to the left pump.
- Disconnect each end of the hose and use the (2) 1/4" jic red plugs provided with the kit to cap the ends of the hose.

**NOTE:** Leave the hose zip tied in the bundle and tuck the ends out of the way.

**TIP:** Disconnect the end from the hopper control valve first and hold the end of the hose up to prevent excess oil spillage. Then turn the end down into a container to drain the rest of the excess oil. Have a rag and or container ready to catch excess oil.

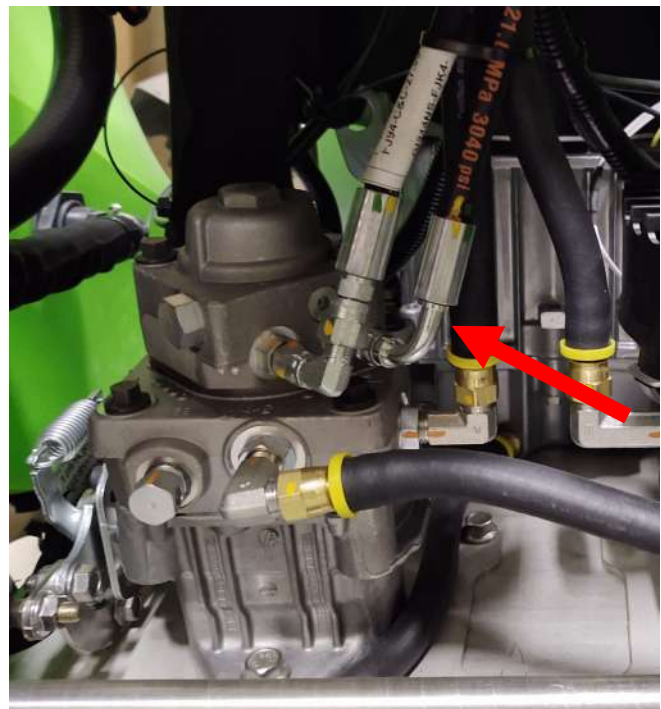
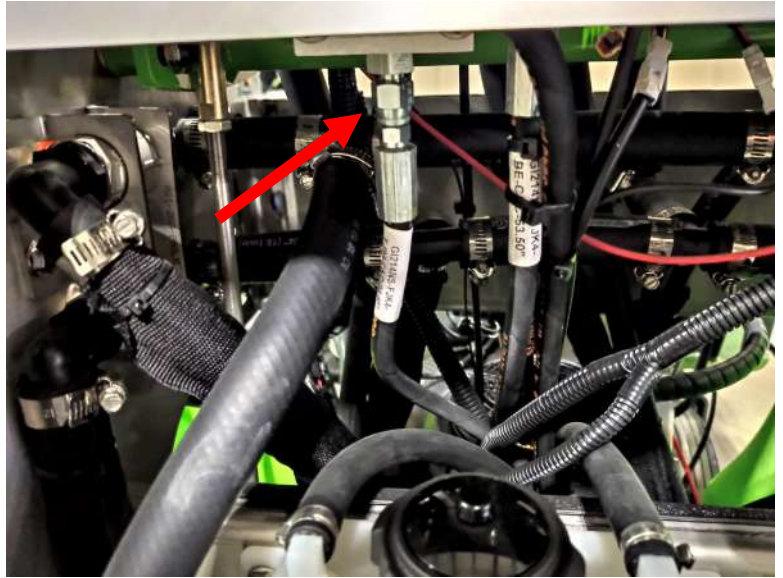

## RAKE ATTACHMENT INSTRUCTIONS

### STEP FOUR:

- Using (1) of the 38" hoses provided with the kit, attach the end with the straight fitting to the return port of the control valve.

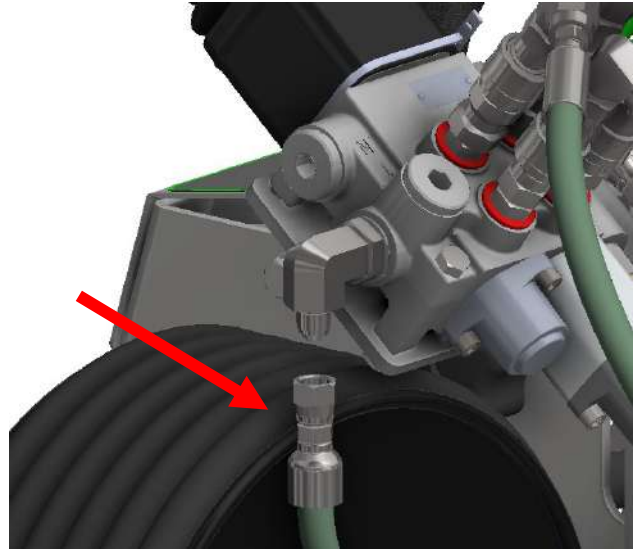

- Attach the other end of the hose to the input port of the hopper control valve. *(end with 90° fitting)*

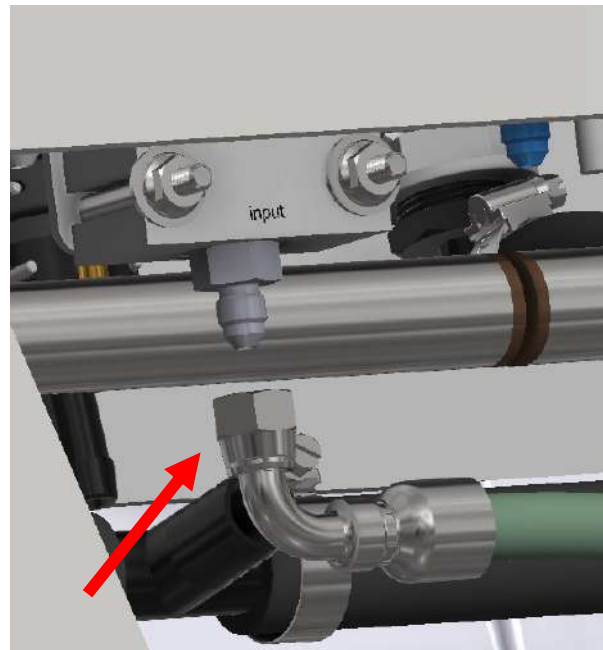

## RAKE ATTACHMENT INSTRUCTIONS

### STEP FIVE:

- Using the other 38" hose provided with the kit, attach the end with the straight fitting to the supply port of the control valve.

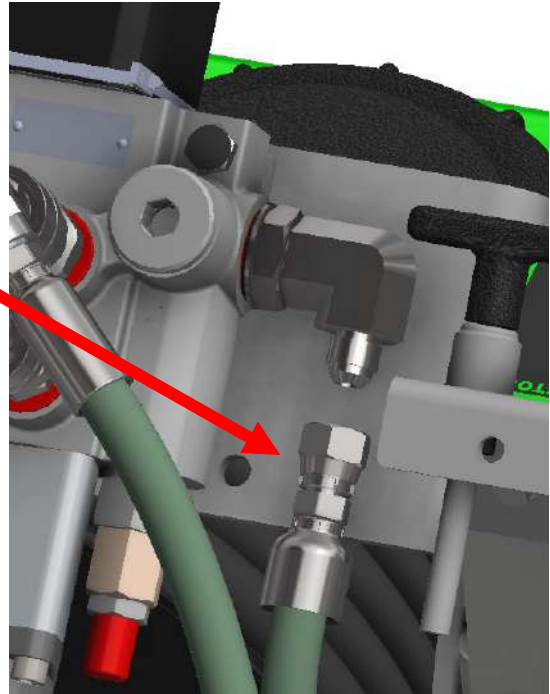

- Attach the other end of the hose to the hydraulic pump. (*end with 90° fitting*)

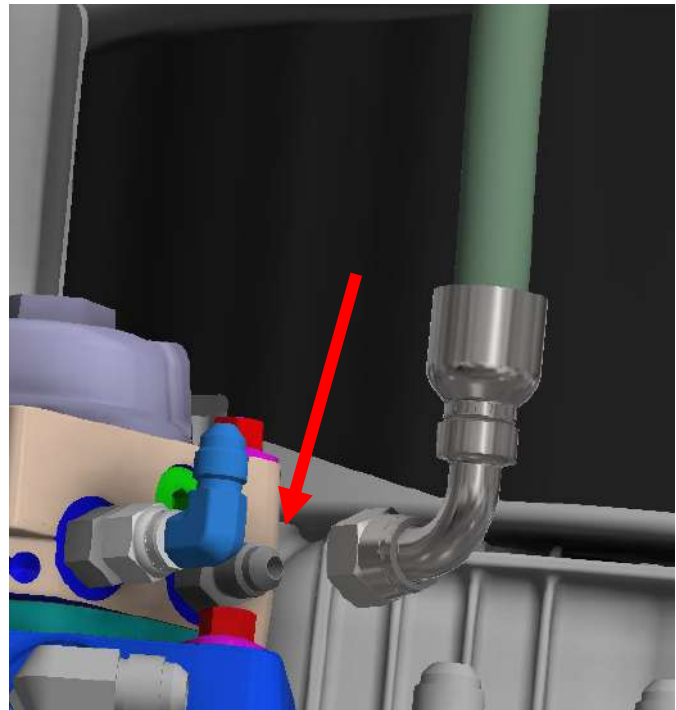

## RAKE ATTACHMENT INSTRUCTIONS

**STEP SIX:** Route the hoses from the plow hitch along the right side of the hopper, up through the opening in the hopper shield, and to the control valve.

**NOTE:** *Zip tie both hose assemblies away from any moving parts to prevent damage.*

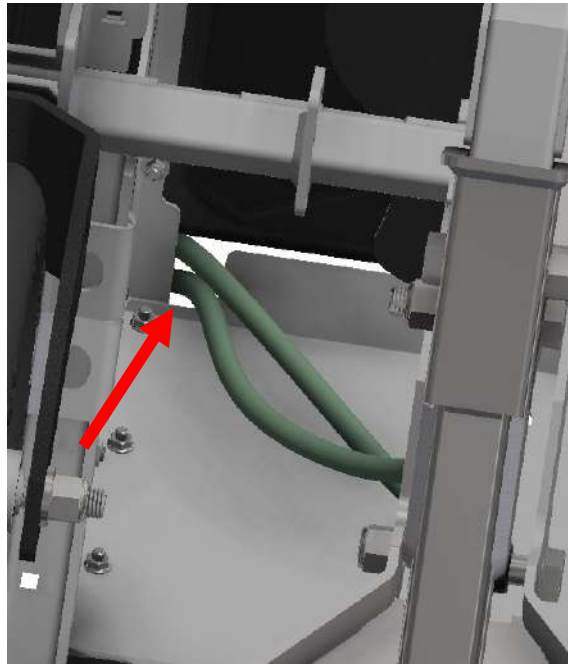



## RAKE ATTACHMENT INSTRUCTIONS

- Connect the hoses from the plow hitch to the *right side (LIFT)* of the control valve.

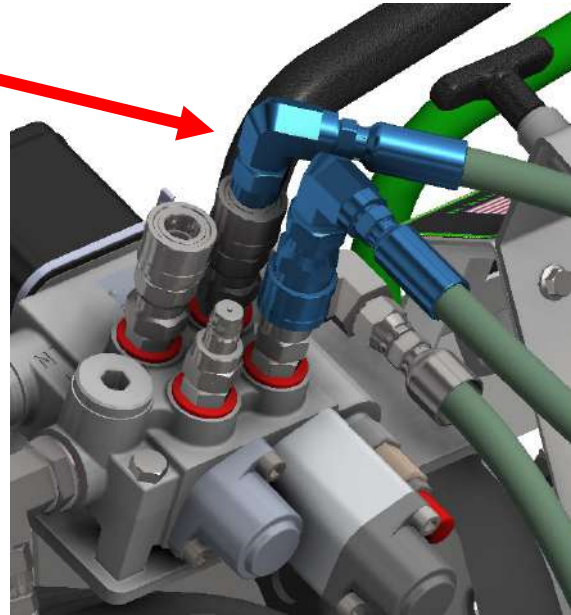

### STEP SEVEN:

- Top off the hydraulic oil tank and start the machine.
- Operate the plow left/right and up/down.

**NOTE:** *The cylinders and control valve are empty so it will take a few cycles to fill them and get the air out of the system.*

- Top off the oil tank as it gets low, it should take approx. (2) quarts.



### CAUTION!

*DO NOT let the machine run out of hydraulic oil*

## RAKE ATTACHMENT INSTRUCTIONS

### STEP EIGHT:

- Attach the rake to the hitch using (1) 5/8" X 3" bolt and nut provided with the kit.





Steel Green Mfg.  
824 S State Road 39  
Lebanon, IN 46052  
(765)-481-2890  
[www.steelgreenmfg.com](http://www.steelgreenmfg.com)

MANUAL PART NO.	MANUAL REV.	DESCRIPTION	KIT PART NO.
SGM-032	B	SG RAKE ATTACHMENT	A10083